

Production Worksheet

Wilcom EmbroideryStudio – Level 3 Advanced

510801 - SEWING 4

Design: 510801 - Sewing 4
Colorway: Colorway 1

Stitches: 11021
Colors: 2
Height: 70.4 mm
Width: 82.9 mm
Zoom: 1:1

Machine: Tajima
Color changes: 1
Stops: 2
Trims: 6
Left: 41.4 mm
Right: 41.4 mm
Up: 35.2 mm
Down: 35.2 mm
EndX: 0.0 mm
EndY: 0.0 mm
Max Stitch: 7.2 mm
Min Stitch: 0.5 mm
Max Jump: 7.0 mm
Total Bobbin: 21.93m

Stop Sequence:

| # | N# | St. | Description | Code | Brand |
|----|----|--------|---------------|------|--------------------|
| 1. | 15 | □ 6542 | Super White | 1001 | Madeira Classic 40 |
| 2. | 13 | ■ 4477 | Emerald Black | 1000 | Madeira Classic 40 |

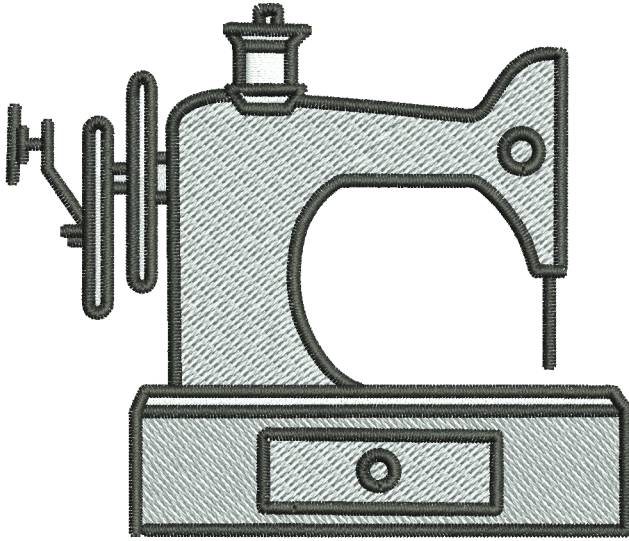

Color Film

Wilcom EmbroideryStudio – Level 3 Advanced

510801 - SEWING 4

Design: 510801 - Sewing 4

Colorway: Colorway 1

Stitches: 11021

Colors: 2

Height: 70.4 mm

Width: 82.9 mm

Zoom: 0.57

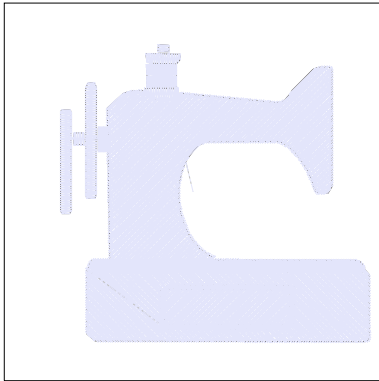

#: 1

Color: Super White

Code: 1001

Brand: Madeira Classic 40

Stitches: 6542

Thread Used: 39.45m

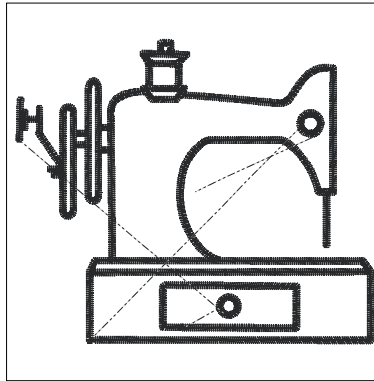

#: 2

Color: Emerald Black

Code: 1000

Brand: Madeira Classic 40

Stitches: 4477

Thread Used: 19.59m